

# Z1099 BACKWATER VALVE BALL FLOAT TYPE

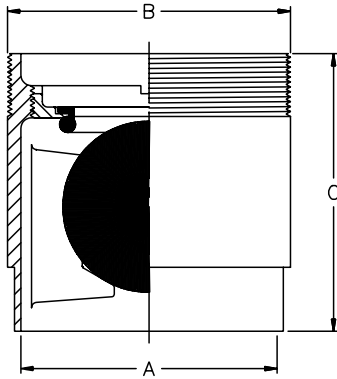

## ENGINEERING SPECIFICATION

Zurn Z1099 backwater valve features Dura-Coated cast iron body, plastic ball float, bronze backwater bushing, and replaceable neoprene seat.



Product Designation	Dimensions in inches [mm]			Approximate Weight lb [kg]
	A Pipe Size	B	C	
-3	3 [76]	3 [76]	6-1/2 [165]	7 [3]
-4	4 [102]	4 [102]		9 [4]
-6	6 [152]	6 [152]		25 [11]

PREFIXES	DESCRIPTION	PIPE SIZE	LIST PRICE
Z1099*	D.C.C.I. Body	3" 4", 6"	<b>Combine with connection type for pricing</b>

CONNECTION DESIGNATION (SPECIFY PIPE SIZE IN INCHES AND TYPE OF CONNECTION)			
PRODUCT DESIG.	CONNECTION TYPE	PIPE SIZE/OUTLET TYPE	ADD
-3	Threaded x No-Hub	3IP x 3NH	580.00
	No-Hub x No-Hub	3NH x 3NH	580.00
-4	Threaded x No-Hub	4IP x 4NH	580.00
	No-Hub x No-Hub	4NH x 4NH	580.00
-6	Threaded x No-Hub	6IP x 6NH	1,199.00
	No-Hub x No-Hub	6NH x 6NH	1,199.00

SUFFIXES	ADD	
-G	Galvanized Cast Iron	
	3", 4"	107.00
	6"	272.00

BEST SELLERS	LIST PRICE
Z1099-3NHX2NH	580.00
Z1099-3NHX3NH	580.00
Z1099-4NHX4NH	580.00

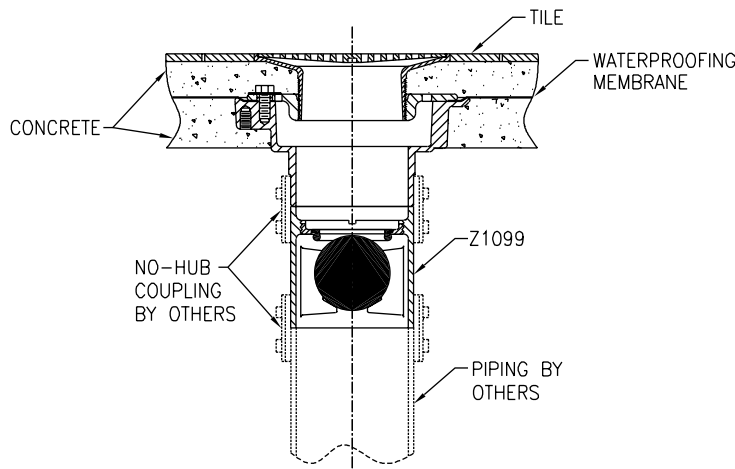

Z1099 shown installed on the outlet of a floor drain. In order for the Z1099 to operate properly, it must always be installed in a vertical position as illustrated.

Supplied By:



877-903-7246

www.commercialplumbingsupply.com